

# Model 390/391 Control Valves

## Technical Sales Bulletin



Figure 1 Model 390 Control Valve

The Model 390/391 control valve (Figure 1) is a heavy duty globe style control valve. This valve is used in all kinds of demanding applications, including oil and gas production and chemical process industries. Metal seats are used for increased seat life.

Model 390/391 valves are balanced cage guided, single port valves that can be used in either snap on/off acting or throttling applications of either liquids or gases. A bolted bonnet is standard and a typical actuator is a Dyna-Flo Model DFC or DFO linear actuators.

### Features

#### High Quality Construction

Dyna-Flo uses only materials that have been proven to provide superior, trouble free performance. All materials comply with ASME and ASTM specifications.

#### Versatility

A wide range of trim options including Anti-Cavitation and Low-Noise make the 390/391 a highly versatile control valve.

#### Field Service Friendly

No special tools are required to change or inspect trim. Top access makes in-line service easy.

#### Industrial High Quality External Coatings

Our standard industrial high quality external coatings provide long lasting resistance to the harshest environments.

#### Pressure Drop Capabilities

The Model 390/391 can shut off against inlet pressures equal to ANSI/FCI 70.2 and IEC 60534-4 rating.

#### Sour Gas Service Capability

The Model 390/391 can be constructed out of materials that comply with the recommendations of the National Association of Corrosion Engineers (NACE) MR0175/ISO 15156.

#### Shut Off Classification

Seat leakage options in accordance with ANSI/FCI 70.2 and IEC 60534-4, range from ANSI Class II to Class VI.

#### Balanced Design

Standard balanced plug design allows the use of smaller actuators.

#### Environmentally Friendly

Available with low emission live loaded PTFE, graphite, and KALREZ® packing.



# Model 390/391 Control Valves

## Technical Sales Bulletin

### SPECIFICATIONS

#### Configurations

The Model 390 control valve is a high capacity single port, globe style valve with a bolted type bonnet. The standard valve plug action is push down to close. Refer to Table 1.

Consult your Dyna-Flo sales office for other available configurations.

#### Sizes and Connection Styles (Refer to Table 1)

Model:	390 & 391
Size:	2", 3", 4", 6"
Body:	Globe (All Sizes), Angle (2" to 6")
Rating:	ASME Class 900 & 1500
Connection:	RF / RTJ / BWE - All Sizes

#### Maximum Inlet Pressures and Temperatures

Flanged valves consistent with ASME Class 900 and 1500 rating as per ASME B16.34, unless limited.

#### Maximum Pressure Drops

**Standard Valve Trim:** Refer to Figure 9.

**Anti-Cavitation 2 Stage Trim:** 2,160 Psi (14,893 kPa).

**Anti-Cavitation 3 Stage Trim:** 3,000 Psi (20,684 kPa).

**Low-Noise Valve Trim:** Figure 9.

#### Characteristic and Flow Direction

- Equal Percentage (Standard) - Flow Down
- Modified Equal Percentage - Flow Down
- Linear - Flow Down
- Low-Noise III (Linear) - Flow Up
- Anti-Cavitation 1-Stage (Linear) - Flow Down
- Anti-Cavitation 2-Stage (Linear) - Flow Down

#### Dimensions

##### Valve and Actuator Outline Dimension Diagram

Refer to Figure 2.

##### Valve and Actuator Assembly Dimensions

Refer to Tables 6 to 11.

#### Approximate Valve Body and Actuator Weights

Refer to Table 5.

#### Materials

Body and bonnet material options include:

LCC (A350-LF2 optional\* bonnet material)

WCC (A350-LF2 optional\* bonnet material)

WC9 (A182-F22 optional\* bonnet material)

CF8M (A182-F316 optional\* bonnet material)

**\*NOTE:** Dyna-Flo reserves the right to substitute a cast material with the forged bar equivalent in the event a casting is not available.

Refer to Figure 9 for valve construction material temperature limitations. Refer to Table 14 for trim selections.

#### Cross-Section of the Model 390 Control Valves

Refer to Figure 3.

#### Port Diameters and Maximum Valve Plug Travel

Refer to Tables 3 and 4.

#### Packing Type and Examples

The Standard packing is PTFE V-ring. Live-loaded low emission, graphite, KALREZ® and other packing arrangements are available. Refer to Figure 8.

#### Maximum Valve Sizing Coefficients

For standard coefficients at maximum travel, refer to Table 18 & 19. For full list of coefficients refer to document P-CVSM.

#### Service Application

Refer to Tables 12 - 17.

For more information and other options contact your Dyna-Flo sales office.

# Model 390/391 Control Valves

## Technical Sales Bulletin



Table 1

### Available Valve Configurations

Valve Model	Valve Size Inch	End Connection			BWE <sup>(3)</sup>
		RF <sup>(1)</sup> and RTJ <sup>(2)</sup> (Flanged)			
		ASME Class 900/1500	ASME Class 900	ASME Class 1500	
390	2	✓	✗	✗	✓
	3 / 4 / 6	✗	✓	✓	✓
390A	2	✓	✗	✗	✓
	3 / 4 / 6	✗	✗	✓	✓
391	2	✓	✗	✗	✓
	3 / 4 / 6	✗	✓	✓	✓
391A	2	✓	✗	✗	✓
	3 / 4 / 6	✗	✗	✓	✓
<b>Notes:</b>	1 - RF = Raised Face.				
	2 - RTJ = Ring Type Joint.				
	3 - BWE = Butt Weld (ASME Class 1500 Only).				

Table 2

### Standard Shut-Off Classifications (in accordance with ANSI/FCI 70.2 and IEC 60534-4)

Valve Model	Seal Option	Port Diameter inch (mm)	Shut-Off Class	
390 & 390A	Spring-Loaded Seal	1-7/8 to 5-3/8 (47.6 to 136.5)	Standard	Class V - up to 450°F (232°C)
			Optional	Class IV
	Spring-Loaded Seal with PEEK <sup>(1)</sup> Anti-Extrusion Rings	1-7/8 to 5-3/8 (47.6 to 136.5)	Standard	Class V - up to 600°F (316°C)
			Optional	Class IV
391 & 391A	Double Piston Rings	1-7/8 (47.6 mm)	Only	Class II
		2-7/8 to 3-5/8 (73.0 to 92.1)	Standard	Class II
			Optional	Class III
	Double Piston Rings	4-3/8 and Larger (111.1 and Larger)	Standard	Class III
	Triple Piston Rings	4-3/8 and Larger (111.1 and Larger)	Optional	Class IV
<b>Notes:</b>	1 - PEEK = PolyEtherEther Ketone.			



# Model 390/391 Control Valves

## Technical Sales Bulletin

Table 3

Globe Valve Port Diameters, Valve Plug Travel and Yoke Boss Diameter

Valve Size	Characteristic	Model	Port Diameter		Maximum Travel		Stem Diameter		Yoke Boss Diameter	
			Inch	mm	Inch	mm	Inch	mm	Inch	mm
2	Equal Percentage	390/391	1-7/8	47.6	1-1/8	28.6	1/2	12.7	2-13/16	71.4
							3/4	19.1	3-9/16	90.5
	Modified Equal Percentage Linear Low-Noise III A1	390/391	1-7/8	47.6	1-1/2	38.1	1/2	12.7	2-13/16	71.4
							3/4	19.1	3-9/16	90.5
	Anti-Cavitation 2 Stage	390	1-3/4	44.5	2	50.8	1/2	12.7	2-13/16	71.4
							3/4	19.1	3-9/16	90.5
3	Equal Percentage	390/391	2-7/8	73.0	1-1/2	38.1	1/2	12.7	2-13/16	71.4
							3/4	19.1	3-9/16	90.5
	Modified Equal Percentage Linear Low-Noise III A1 / B1	390/391	2-7/8	73.0	2	50.8	1/2	12.7	2-13/16	71.4
							3/4	19.1	3-9/16	90.5
	Anti-Cavitation 2 Stage	390	2-1/2	63.5	2-1/2	63.5	1/2	12.7	2-13/16	71.4
							3/4	19.1	3-9/16	90.5
	Anti-Cavitation 3 Stage	390	1-7/8	47.6	2-1/2	63.5	1/2	12.7	2-13/16	71.4
							3/4	19.1	3-9/16	90.5
4	Equal Percentage	390/391	3-5/8	92.1	1-1/2	38.1	3/4	19.1	3-9/16	90.5
							1	25.4	5	127
	Modified Equal Percentage Linear Low-Noise III A1 / B1 / C3	390/391	3-5/8	92.1	2	50.8	3/4	19.1	3-9/16	90.5
							1	25.4	5	127
	Low-Noise III D3	390/391	2-7/8	73.0	2	50.8	3/4	19.1	3-9/16	90.5
							1	25.4	5	127
	Anti-Cavitation 2 Stage	390	3-7/16	87.3	3	76.2	3/4	19.1	3-9/16	90.5
							1	25.4	5	127
	Anti-Cavitation 3 Stage	390	2-7/8	73.0	3	76.2	3/4	19.1	3-9/16	90.5
							1	25.4	5	127
6	Equal Percentage	390/391	5-3/8	136.5	2-1/2	63.5	3/4	19.1	3-9/16	90.5
							1	25.4	5	127
	Modified Equal Percentage Linear Low-Noise III A1 / B1 / C3	390/391	5-3/8	136.5	3	76.2	3/4	19.1	3-9/16	90.5
							1	25.4	5	127
	Low-Noise III D1	390/391	4-3/8	111.1	3	76.2	3/4	19.1	3-9/16	90.5
							1	25.4	5	127
	Anti-Cavitation 2 Stage	390	5-1/4	133.4	4	101.6	3/4	19.1	3-9/16	90.5
							1	25.4	5	127
	Anti-Cavitation 3 Stage	390	4-9/16	115.9	4	101.6	3/4	19.1	3-9/16	90.5
							1	25.4	5	127

# Model 390/391 Control Valves



Table 4

Angle Valve Port Diameters, Valve Plug Travel and Yoke Boss Diameter

Valve Size	Characteristic	Model	Port Diameter		Maximum Travel		Stem Diameter		Yoke Boss Diameter	
			Inch	mm	Inch	mm	Inch	mm	Inch	mm
2	Equal Percentage	390/391	1-7/8	47.6	1-1/8	28.6	1/2	12.7	2-13/16	71.4
							3/4	19.1	3-9/16	90.5
	Modified Equal Percentage Linear Low-Noise III A1	390/391	1-7/8	47.6	1-1/2	38.1	1/2	12.7	2-13/16	71.4
							3/4	19.1	3-9/16	90.5
	Anti-Cavitation 2 Stage	390	1-3/4	44.5	2	50.8	1/2	12.7	2-13/16	71.4
							3/4	19.1	3-9/16	90.5
3	Equal Percentage	390/391	1-7/8	47.6	1-1/8	28.6	1/2	12.7	2-13/16	71.4
							3/4	19.1	3-9/16	90.5
	Modified Equal Percentage Linear Low-Noise III A1	390/391	1-7/8	47.6	1-1/2	38.1	1/2	12.7	2-13/16	71.4
							3/4	19.1	3-9/16	90.5
	Anti-Cavitation 2 Stage	390	1-3/4	44.5	2	50.8	1/2	12.7	2-13/16	71.4
							3/4	19.1	3-9/16	90.5
4	Equal Percentage	390/391	2-7/8	73.0	1-1/2	38.1	3/4	19.1	3-9/16	90.5
							1	25.4	5	127
	Modified Equal Percentage Linear Low-Noise III A1 / B1	390/391	2-7/8	73.0	2	50.8	3/4	19.1	3-9/16	90.5
							1	25.4	5	127
	Anti-Cavitation 2 Stage	390	2-1/2	63.5	2-1/2	63.5	3/4	19.1	3-9/16	90.5
							1	25.4	5	127
Anti-Cavitation 3 Stage	390	1-7/8	47.6	2-1/2	63.5	3/4	19.1	3-9/16	90.5	
						1	25.4	5	127	
6	Equal Percentage	390/391	3-5/8	92.1	1-1/2	38.1	3/4	19.1	3-9/16	90.5
							1	25.4	5	127
	Modified Equal Percentage Linear Low-Noise III A1 / B1 / C3	390/391	3-5/8	92.1	2	50.8	3/4	19.1	3-9/16	90.5
							1	25.4	5	127
	Low-Noise III D1	390/391	2-7/8	73.0	2	50.8	3/4	19.1	3-9/16	90.5
							1	25.4	5	127
Anti-Cavitation 2 Stage	390	3-7/16	87.3	3	76.2	3/4	19.1	3-9/16	90.5	
						1	25.4	5	127	
Anti-Cavitation 3 Stage	390	2-7/8	73.0	3	76.2	3/4	19.1	3-9/16	90.5	
						1	25.4	5	127	

# Model 390/391 Control Valves



Table 5

## Globe Valve Approximate Weights lb (kg)

Valve Size (Inch)	Class	Body	
		Flanged	BWE
2	900 / 1500	160 (73)	115 (52)
3	900	275 (125)	—
3	1500	286 (130)	213 (97)
4	900	510 (231)	—
4	1500	552 (250)	444 (201)
6	900	1125 (510)	—
6	1500	1228 (557)	1003 (455)

## Angle Valve Approximate Weights lb (kg)

Valve Size	Class	Body	
		Flanged	BWE
2	900 / 1500	153 (69)	110 (50)
3	1500	272 (123)	173 (78)
4	1500	399 (181)	258 (117)
6	1500	788 (357)	445 (202)

# Model 390/391 Control Valves

## Technical Sales Bulletin



Table 6

### Standard Globe Valve Dimensions Inches (mm)

(Refer to Figure 2)

Valve Size (Inch)	ASME Class	Actuator Size	A	G	B	D		E
						DFC	DFO	
2	900 / 1500 RF	2105	14.75 (375)	7.38 (187)	3.06 (78)	30.25 (768)	25.72 (653)	16.00 (406)
	900 / 1500 RTJ	2105	14.88 (378)	7.44 (189)	3.06 (78)	30.25 (768)	25.72 (653)	16.00 (406)
	900 / 1500 BWE	2105	14.75 (375)	7.38 (187)	3.06 (78)	30.25 (768)	25.72 (653)	16.00 (406)
3	900 RF	2105	17.38 (441)	8.69 (221)	4.75 (121)	30.25 (768)	25.72 (653)	16.00 (406)
	900 RTJ	2105	17.50 (445)	8.75 (222)	4.75 (121)	30.25 (768)	25.72 (653)	16.00 (406)
	1500 RF	2156	18.13 (460)	9.06 (230)	4.75 (121)	30.25 (768)	25.72 (653)	18.62 (473)
	1500 RTJ	2156	18.25 (464)	9.12 (232)	4.75 (121)	30.25 (768)	25.72 (653)	18.62 (473)
	1500 BWE	2156	18.13 (460)	9.06 (230)	4.75 (121)	30.25 (768)	25.72 (653)	18.62 (473)
3	900 RF	3156	17.38 (441)	8.69 (221)	4.75 (121)	30.91 (785)	28.10 (714)	18.62 (473)
	900 RTJ	3156	17.50 (445)	8.75 (222)	4.75 (121)	30.91 (785)	28.10 (714)	18.62 (473)
	1500 RF	3156	18.13 (461)	9.06 (230)	4.75 (121)	30.91 (785)	28.10 (714)	18.62 (473)
	1500 RTJ	3156	18.25 (464)	9.12 (232)	4.75 (121)	30.91 (785)	28.10 (714)	18.62 (473)
	1500 BWE	3156	18.13 (460)	9.06 (230)	4.75 (121)	30.91 (785)	28.10 (714)	18.62 (473)
4	900 RF	3156	20.12 (511)	9.00 (229)	6.88 (175)	30.91 (785)	28.10 (714)	18.62 (473)
	900 RTJ	3156	20.25 (514)	9.06 (230)	6.88 (175)	30.91 (785)	28.10 (714)	18.62 (473)
	1500 RF	3220	20.88 (530)	9.51 (242)	6.88 (175)	36.48 (927)	32.69 (830)	21.12 (536)
	1500 RTJ	3220	21.00 (533)	9.44 (240)	6.88 (175)	36.48 (927)	32.69 (830)	21.12 (536)
	1500 BWE	3220	20.88 (530)	9.38 (238)	6.88 (175)	36.48 (927)	32.69 (830)	21.12 (536)
6	900 RF	3220	28.12 (714)	12.19 (310)	9.75 (248)	36.48 (927)	32.69 (830)	21.12 (536)
	900 RTJ	3220	28.25 (718)	12.25 (311)	9.75 (248)	36.48 (927)	32.69 (830)	21.12 (536)
	1500 RF	3220	30.25 (768)	13.25 (337)	9.75 (248)	36.48 (927)	32.69 (830)	21.12 (536)
	1500 RTJ	3220	30.50 (775)	13.38 (340)	9.75 (248)	36.48 (927)	32.69 (830)	21.12 (536)
	1500 BWE	3220	30.25 (768)	13.25 (337)	9.75 (248)	36.48 (927)	32.69 (830)	21.12 (536)



# Model 390/391 Control Valves

## Technical Sales Bulletin

Table 7

### Dimension C for Globe Valves with Standard Bonnets

Inch (mm) (Refer to Figure 2)

Valve Size (Inch)	Dimension C			
	ASME Class	2-13/16 (71) Yoke Boss Diameter	3-9/16 (90) Yoke Boss Diameter	5 (127) Yoke Boss Diameter
2	900 / 1500	10.31 (261)	10.56 (267)	—
2 Anti-Cavitation 2 Stage	900 / 1500	11.00 (279)	11.25 (286)	—
3	900 / 1500	12.69 (322)	12.25 (311)	—
4	900 / 1500	—	11.81 (300)	14.50 (368)
6	900 / 1500	—	14.38 (365)	15.81 (402)

Table 8

### Dimension C for Globe Valves with Extension Style 1 Bonnets

Inch (mm) (Refer to Figure 2)

Valve Size (Inch)	Dimension C		
	2-13/16 (71) Yoke Boss Diameter	3-9/16 (90) Yoke Boss Diameter	5 (127) Yoke Boss Diameter
2	16.91 (430)	17.53 (445)	—
2 Anti-Cavitation 2 Stage	17.59 (447)	18.22 (463)	—

Table 9

### Dimension C for Angle Valves with Standard Bonnets

Inch (mm) (Refer to Figure 2)

Valve Size (Inch)	Dimension C			
	ASME Class	2-13/16 (71) Yoke Boss Diameter	3-9/16 (90) Yoke Boss Diameter	5 (127) Yoke Boss Diameter
2	900 / 1500	8.94 (277)	9.19 (233)	—
2 Anti-Cavitation 2 Stage	900 / 1500	9.62 (244)	9.88 (251)	—
3	900 / 1500	10.19 (259)	10.44 (265)	—
4	900 / 1500	11.38 (289)	10.94 (278)	13.25 (337)
6	900 / 1500	—	11.81 (300)	14.50 (368)

Table 10

### Dimension C for Angle Valves with Extension Bonnets

Inch (mm) (Refer to Figure 2)

Valve Size (Inch)	Dimension C			
	ASME Class	2-13/16 (71) Yoke Boss Diameter	3-9/16 (90) Yoke Boss Diameter	5 (127) Yoke Boss Diameter
2	900 / 1500	15.56 (395)	16.19 (411)	—
2 Anti-Cavitation 2 Stage	900 / 1500	16.25 (413)	16.88 (429)	—



# Model 390/391 Control Valves

## Technical Sales Bulletin

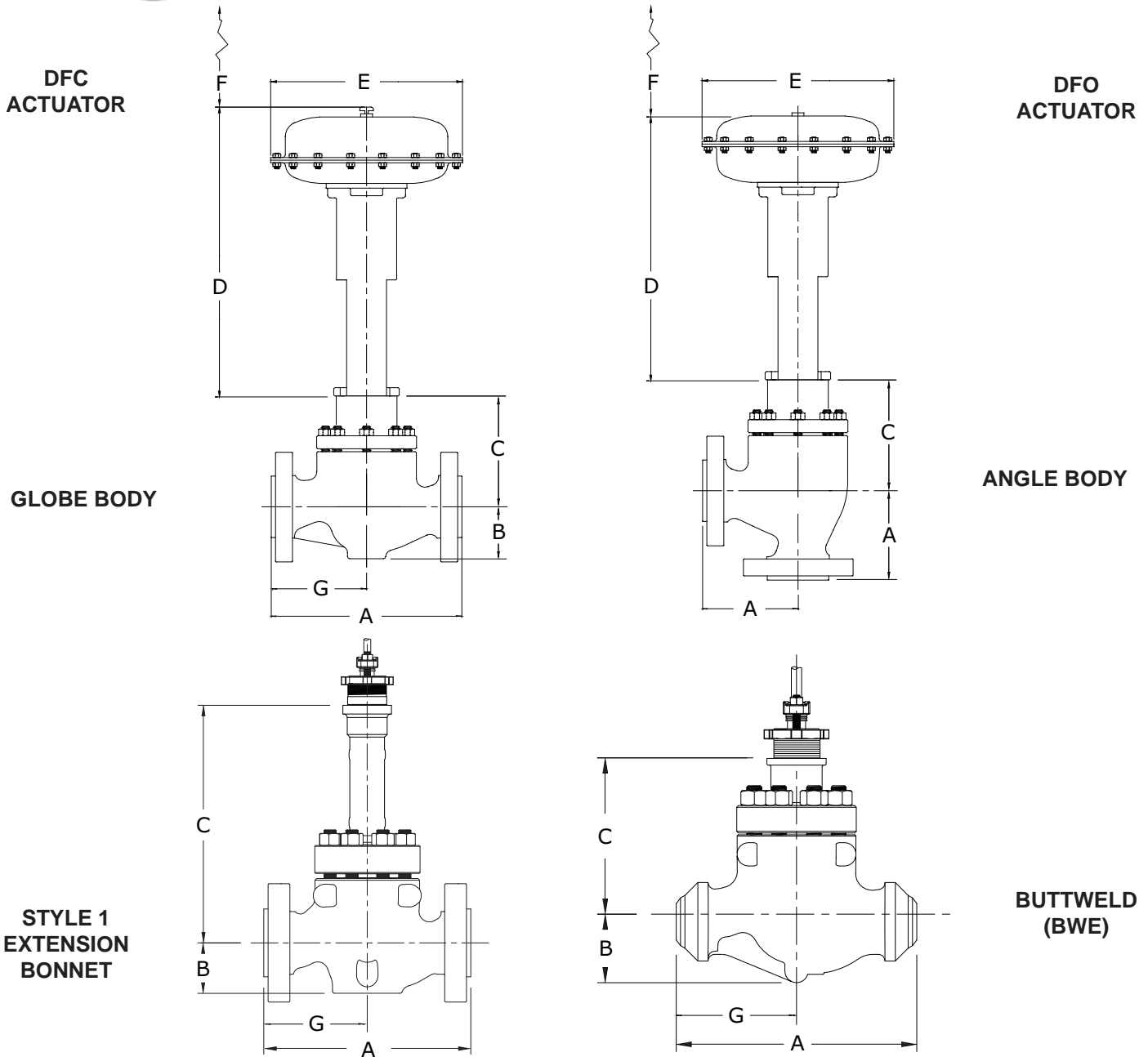

Table 11

**Standard Angle Valve Dimensions Inches (mm)**  
(Refer to Figure 2)

Valve Size (Inch)	ASME Class	Actuator Size	A	D		E
				DFC	DFO	
2	900 RF	2105	7.00 (178)	30.25 (768)	25.72 (653)	16.00 (406)
	900 RTJ	2105	7.06 (179)	30.25 (768)	25.72 (653)	16.00 (406)
	1500 RF	2105	7.00 (178)	30.25 (768)	25.72 (653)	16.00 (406)
	1500 RTJ	2105	7.06 (179)	30.25 (768)	25.72 (653)	16.00 (406)
	1500 BWE	2105	7.00 (178)	30.25 (768)	25.72 (653)	16.00 (406)
3	900 RF	2105	8.88 (226)	30.25 (768)	25.72 (653)	16.00 (406)
	900 RTJ	2105	8.94 (227)	30.25 (768)	25.72 (653)	16.00 (406)
	1500 RF	2156	9.25 (235)	30.25 (768)	25.72 (653)	18.62 (473)
	1500 RTJ	2156	9.31 (236)	30.25 (768)	25.72 (653)	18.62 (473)
	1500 BWE	2156	9.25 (235)	30.25 (768)	25.72 (653)	18.62 (473)
3	900 RF	3156	8.88 (226)	30.91 (785)	28.10 (714)	18.62 (473)
	900 RTJ	3156	8.94 (227)	30.91 (785)	28.10 (714)	18.62 (473)
	1500 RF	3156	9.25 (235)	30.91 (785)	28.10 (714)	18.62 (473)
	1500 RTJ	3156	9.31 (236)	30.91 (785)	28.10 (714)	18.62 (473)
	1500 BWE	3156	9.25 (235)	30.91 (785)	28.10 (714)	18.62 (473)
4	900 RF	3156	10.75 (273)	30.91 (785)	28.10 (714)	18.62 (473)
	900 RTJ	3156	10.81 (275)	30.91 (785)	28.10 (714)	18.62 (473)
	1500 RF	3220	10.75 (273)	36.48 (927)	32.69 (830)	21.12 (536)
	1500 RTJ	3220	10.81 (275)	36.48 (927)	32.69 (830)	21.12 (536)
	1500 BWE	3220	10.75 (273)	36.48 (927)	32.69 (830)	21.12 (536)
6	900 RF	3220	12.81 (325)	36.48 (927)	32.69 (830)	21.12 (536)
	900 RTJ	3220	12.88 (327)	36.48 (927)	32.69 (830)	21.12 (536)
	1500 RF	3220	13.88 (353)	36.48 (927)	32.69 (830)	21.12 (536)
	1500 RTJ	3220	14.00 (356)	36.48 (927)	32.69 (830)	21.12 (536)
	1500 BWE	3220	13.88 (353)	36.48 (927)	32.69 (830)	21.12 (536)

# Model 390/391 Control Valves



### F Dimension

2" Valve - 6.88" (175 mm)	4" Valve - 9.12" (232 mm)
3" Valve - 6.88" (175 mm)	6" Valve - 9.12" (232 mm)
3" Valve - 9.12" (232 mm) For DFC/DFO 3156	

Figure 2 Typical Valve Assembly Diagrams

# Model 390/391 Control Valves



**NOTE:** BONNET ROTATED 90° FOR CLARITY.

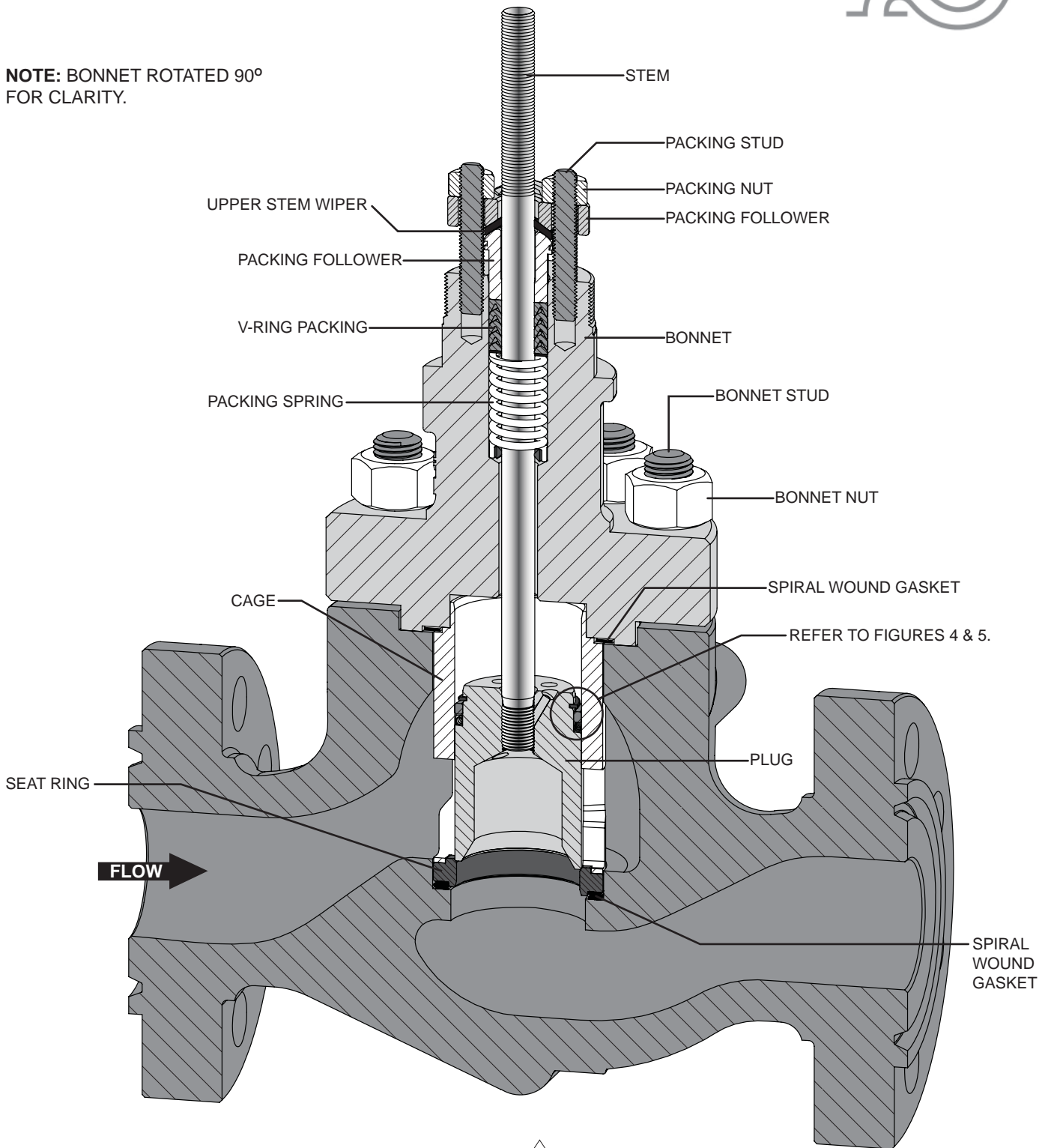
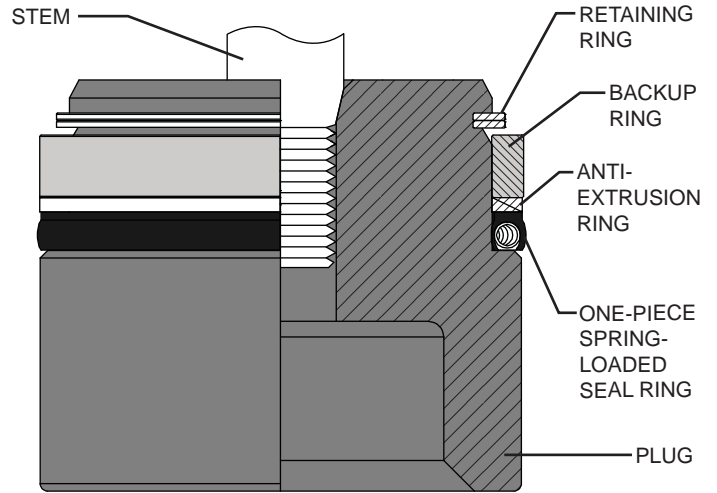
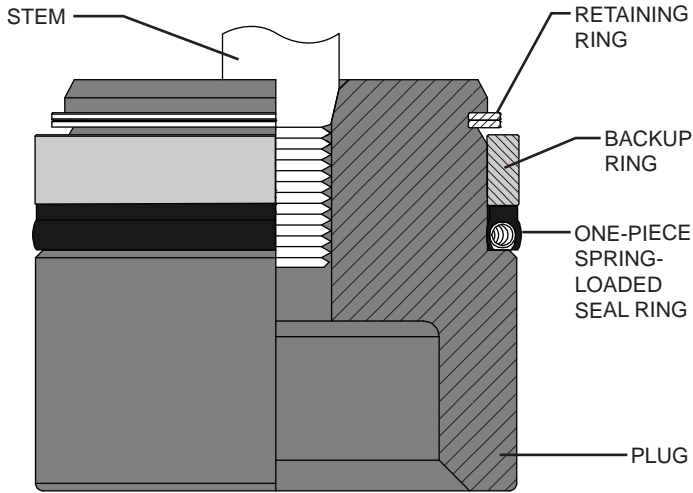

**Figure 3** Cross-section of 390 Series Control Valve with Standard Trim and Packing



# Model 390/391 Control Valves

## Technical Sales Bulletin



**Figure 4** Spring-Loaded Plug Seal Arrangement

**Figure 5** Spring-Loaded Plug Seal with Anti-Extrusion Ring

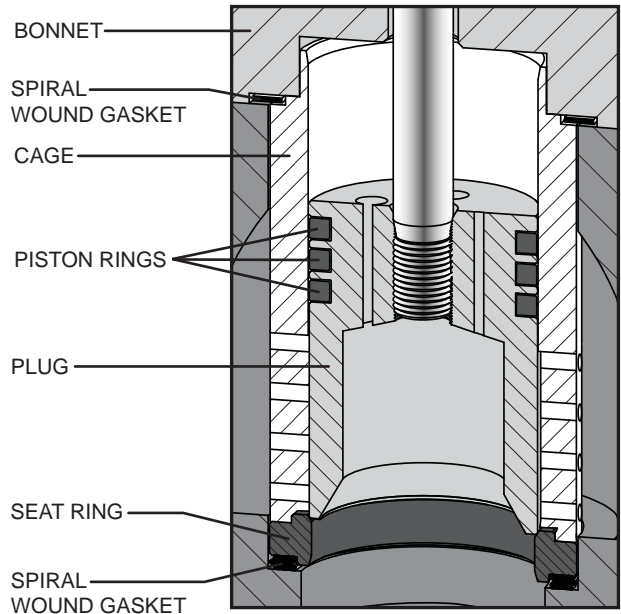
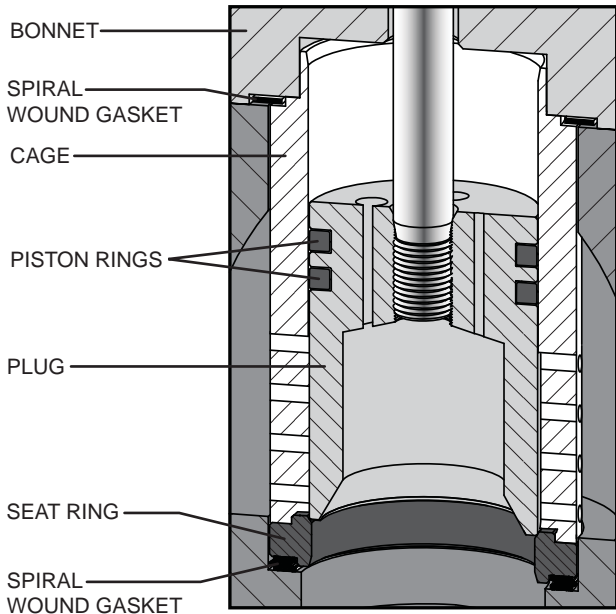

**Figure 6** Model 391 Standard Assembly Detail

**Figure 7** Model 391 Triple Piston Ring Detail (Class IV)

# Model 390/391 Control Valves

## Technical Sales Bulletin

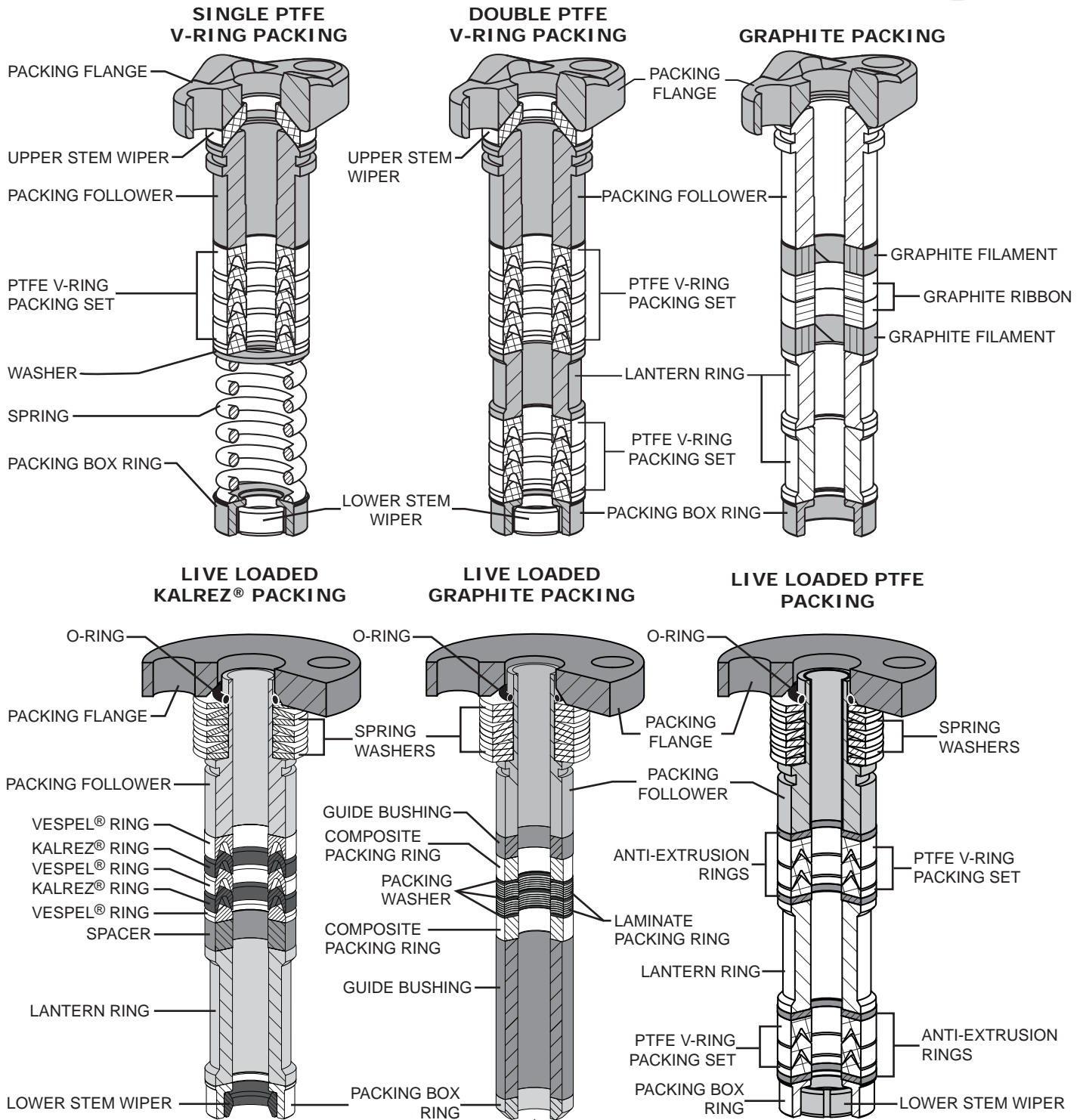

Figure 8 Typical Packing Arrangements



# Model 390/391 Control Valves

## Technical Sales Bulletin

Table 12

### Common Valve Parts Typical Construction Materials and Temperature Limitations

Part	Material	Temperature Limitations				
		Min. °F	Max. °F	Min. °C	Max. °C	
Valve Stem	S20910	NLF <sup>(3)</sup>	NLF <sup>(3)</sup>	NLF <sup>(3)</sup>	NLF <sup>(3)</sup>	
Spring-Loaded (Three-Piece) Valve Plug Seal <sup>(1)</sup> (390 Only)	Backup Ring	S31600/S31603 Dual Grade	NLF <sup>(3)</sup>	NLF <sup>(3)</sup>	NLF <sup>(3)</sup>	NLF <sup>(3)</sup>
	Seal Ring	Carbon-filled PTFE / Elgiloy	-100	450	-73	232
	Retaining Ring	S31600	NLF <sup>(3)</sup>	NLF <sup>(3)</sup>	NLF <sup>(3)</sup>	NLF <sup>(3)</sup>
Spring-Loaded (Three-Piece) Valve Plug Seal with Anti-Extrusion Rings <sup>(2)</sup> (390 Only)	Anti-Extrusion Ring	PolyEtherEtherKetone (PEEK)	NLF <sup>(3)</sup>	NLF <sup>(3)</sup>	NLF <sup>(3)</sup>	NLF <sup>(3)</sup>
	Backup Ring	S31600/S31603 Dual Grade	NLF <sup>(3)</sup>	NLF <sup>(3)</sup>	NLF <sup>(3)</sup>	NLF <sup>(3)</sup>
	Seal Ring	Carbon-filled PTFE / Elgiloy	-100	600	-73	316
	Retaining Ring	S31600	NLF <sup>(3)</sup>	NLF <sup>(3)</sup>	NLF <sup>(3)</sup>	NLF <sup>(3)</sup>
Piston Ring (391 Only)	Graphite	-50	NLF <sup>(4)</sup>	-46	NLF <sup>(4)</sup>	
Spiral Wound Gaskets	N06600 / Graphite	-325	800	-198	427	
Packing	PTFE V-Ring	-50	450	-46	232	
	Graphite (Ribbon/Filament)	-325	1000 <sup>(5)</sup>	-198	537 <sup>(5)</sup>	
Packing Follower / Lantern Ring / Packing Box Ring	S31600/S31603 Dual Grade	NLF <sup>(3)</sup>	NLF <sup>(3)</sup>	NLF <sup>(3)</sup>	NLF <sup>(3)</sup>	
Packing Spring	S30400	NLF <sup>(3)</sup>	NLF <sup>(3)</sup>	NLF <sup>(3)</sup>	NLF <sup>(3)</sup>	
Packing Stud	B8M	NLF <sup>(3)</sup>	NLF <sup>(3)</sup>	NLF <sup>(3)</sup>	NLF <sup>(3)</sup>	
Packing Nut	8M	NLF <sup>(3)</sup>	NLF <sup>(3)</sup>	NLF <sup>(3)</sup>	NLF <sup>(3)</sup>	

**NOTES:**

- 1 - Standard for 2 to 6 inch 390 valves.
- 2 - Optional for 390 valves to allow for a maximum temperature limitation of 600°F (316°C) for non-oxidizing service, and 500°F (260°C) for oxidizing service.
- 3 - NLF - This Material is Not A Limiting Factor. For the temperature limitation refer to the valve body material temperature limit.
- 4 - Oxidizing service limited to 1000°F (538°C).
- 5 - Oxidizing service limited to 700°F (371°C).

# Model 390/391 Control Valves

## Technical Sales Bulletin



Table 13

### Body to Bonnet Bolting Temperature Limitations

Body Material	ASME Class	Bolt/Nut Material	Temperature Limitations			
			Min. °F	Max. °F	Min. °C	Max. °C
LCC	150/300/600	B7/2H <sup>(1)(2)</sup>	-50	650	-46	343
		B7M/2HM <sup>(3)</sup>	-50	650	-46	343
WCC/WC9	150/300/600	B7/2H <sup>(1)(2)</sup>	-20	800	-29	427
		B7M/2HM <sup>(3)</sup>	-20	800	-29	427
CF8M	150/300/600	B7 Fluorokote #1 / 2H Fluorokote #1 (Standard) <sup>(2)</sup>	-50	500	-46	260
		B8M/8M <sup>(2)</sup>	-325	800	-198	427
		B7M Fluorokote #1/ 2HM Fluorokote #1 <sup>(3)</sup>	-50	500	-46	260

**NOTES:**

- 1 - Standard non-NACE option.
- 2 - NACE MR0175/ISO15156 Non-Exposed Bolting option (Bolting that is not directly exposed to sour environments and is not to be buried, insulated, equipped with flange protectors, or otherwise denied direct atmospheric exposure).
- 3 - NACE MR0175/ISO15156 Exposed Bolting option (Bolting that will be exposed directly to the sour environment or that will be buried, insulated, equipped with flange protectors, or otherwise denied direct atmospheric exposure).

Table 14

### Trim Options (Refer to Figure 9 for Pressure / Temperature Limits)

Trim Spec	Valve Plug	Stem	Cage	Seat Ring	Service
S	S41600 HT	S20910	S17400 H900	S41600 HT	Standard / Non-corrosive / High Temp
N	S31600 <sup>(1)</sup> / ALLOY 6 Seat and Guide	S20910	S17400 DH1150	S31600 <sup>(1)</sup> / ALLOY 6	Corrosive / NACE <sup>(3)</sup> High Temperature
C	S31600 <sup>(1)</sup> / ALLOY 6 Seat and Guide	S20910	S31600 <sup>(1)</sup> / ENC <sup>(2)</sup>	S31600 <sup>(1)</sup> / ALLOY 6	General / Mild Corrosive
A	S44004 HT	S20910	S17400 H900	S44004 HT	Standard / Non-corrosive / Tight Shut off

**NOTE:**

- 1 - All S31600 barstock is dual grade S31600/S31603 (316/316L).
- 2 - ENC = Electroless Nickel Coating.
- 3 - Metal trim parts compatible with NACE MR0175/ISO 15156. Environmental restrictions may apply.



# Model 390/391 Control Valves

## Technical Sales Bulletin

Table 15

**Valve Body/Trim Option Temperature Limitations (Refer to Figure 9 for Pressure/Temperature limits)**

Refer to Tables 9, 10, & 11 of other limiting factors.

Body Material	Trim Designation	Temperature Limitations			
		Min. °F	Max. °F	Min. °C	Max. °C
LCC	S, A	-20	650	-29	343
	N	-50	650	-46	343
CF8M	A	-20	650 <sup>(1)</sup>	-29	343 <sup>(1)</sup>
	C	-50	600	-46	316
WCC	S, A	-20	650 <sup>(1)</sup>	-29	343 <sup>(1)</sup>
	N	-20	800	-29	427
WC9	S, A	-20	650 <sup>(1)</sup>	-29	343 <sup>(1)</sup>
	N	-20	800	-29	427

**NOTES:**

1 - Trim temperature limitations can be extended to 800°F (427°C) when used in 2 inch size valve bodies.



# Model 390/391 Control Valves

## Technical Sales Bulletin

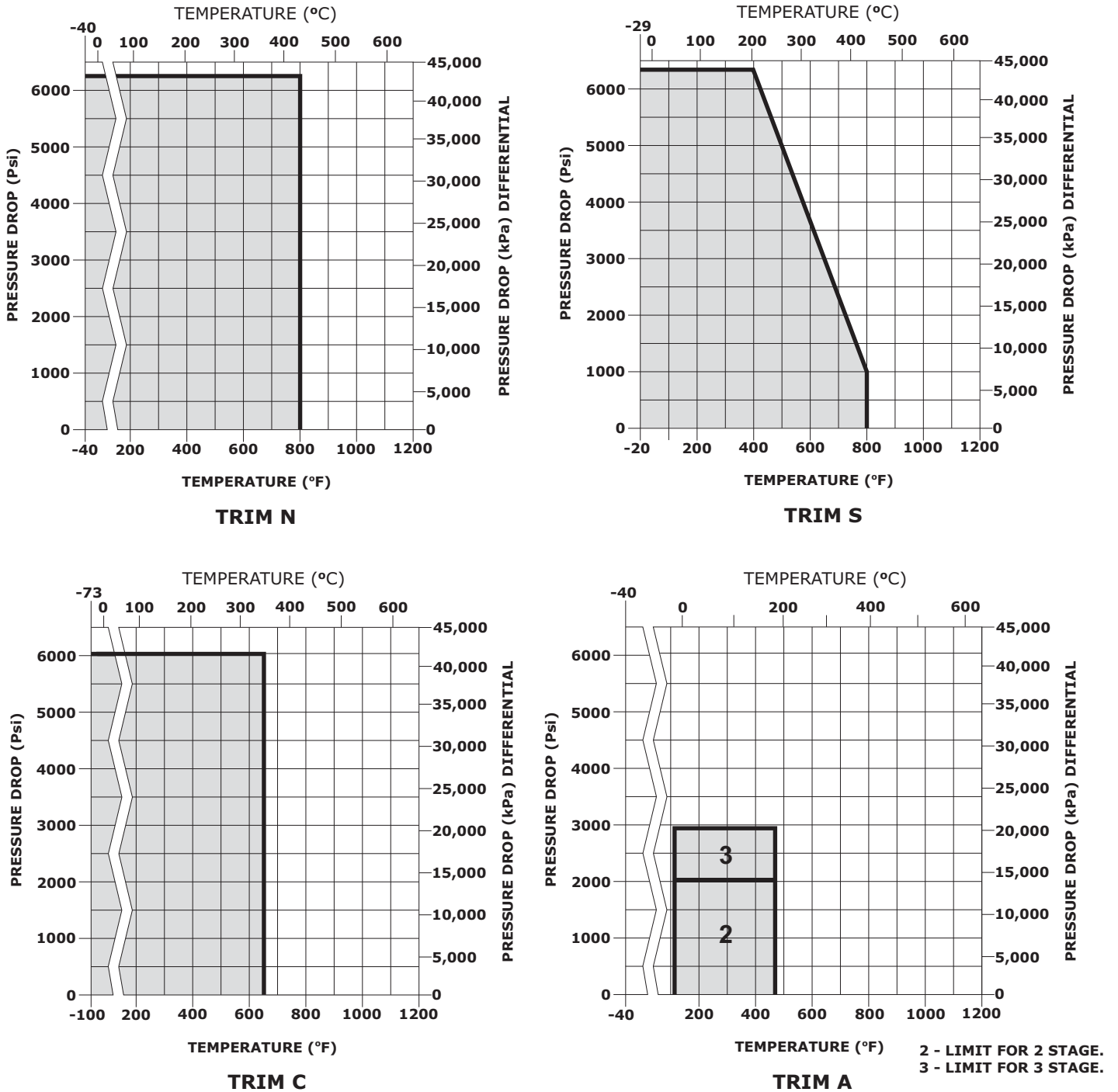

Figure 9 Trim Material Pressure / Temperature Limitations



# Model 390/391 Control Valves

## Technical Sales Bulletin

Table 16

**Shut Off Capabilities for Model 390 with Fail Open Actuator**  
**Metal Seat, Class IV Control Valve**  
**35 psig supply pressure**

Valve Size (inch)	Actuator Size				
	Pressure Drop Psig (kPag)				
	DFO - 2105	DFO - 2156	DFO - 3105	DFO - 3156	DFO - 3220
2	3,750 (25,855) <sup>1</sup>	3,750 (25,855) <sup>1</sup>	—	—	—
3	3,750 (25,855) <sup>2</sup>	37,50 (25,855) <sup>1</sup>	3,750 (25,855) <sup>2</sup>	3,750 (25,855) <sup>1</sup>	—
4	—	—	—	3,750 (25,855) <sup>3</sup>	3,750 (25,855) <sup>1</sup>
6	—	—	—	—	2,280 (15,720) <sup>4</sup>

**Note**

- 1 - 6 to 26 Psig (41 to 179 kPag) bench range
- 2 - 6 to 24 Psig (41 to 165 kPag) bench range
- 3 - 6 to 22 Psig (41 to 152 kPag) bench range
- 4 - 6 to 17 Psig (41 to 117 kPag) bench range

Table 17

**Shut Off Capabilities for Model 390 with Fail Closed Actuator**  
**Metal Seat, Class IV Control Valve**  
**35 psig supply pressure**

Valve Size (inch)	Actuator Size				
	Pressure Drop Psig (kPag)				
	DFC - 2105	DFC - 2156	DFC - 3105	DFC - 3156	DFC - 3220
2	3,750 (25,855) <sup>1</sup>	3,750 (25,855) <sup>1</sup>	—	—	—
3	3,750 (25,855) <sup>2</sup>	3,750 (25,855) <sup>1</sup>	3,750 (25,855) <sup>2</sup>	3,750 (25,855) <sup>1</sup>	—
4	—	—	—	2,280 (15,720) <sup>2</sup>	3,750 (25,855) <sup>3</sup>
6	—	—	—	—	2,280 (15,720) <sup>4</sup>

**Note**

- 1 - 6 to 30 psig (41 to 207 kPag) Bench Range
- 2 - 9 to 30 psig (62 to 207 kPag) Bench Range
- 3 - 15 to 30 psig (103 to 207 kPag) Bench Range
- 4 - 18 to 30 Psig (124 to 207 kPag) Bench Range with a DFC4-3220 Actuator

# Model 390/391 Control Valves

## Technical Sales Bulletin



Table 18

**Maximum Sizing Coefficients**  
**Equal Percentage Characteristic**  
**Globe Body Valve**  
**Flow Down**

Valve Size Inches	Port Inches (mm)	Travel Inches (mm)	Coefficient	Percentage of Valve Travel
				100%
2	1-7/8 (47.6)	1-1/8 (28.6)	C <sub>v</sub>	41.0
3	2-7/8 (73)	1-1/2 (38.1)	C <sub>v</sub>	92.5
4	3-5/8 (92.1)	1-1/2 (38.1)	C <sub>v</sub>	164
6	5-3/8 (136.5)	2-1/2 (63.5)	C <sub>v</sub>	319

**NOTE:** For full list of sizing coefficients refer to document P-CVSM.

Table 19

**Maximum Sizing Coefficients**  
**Equal Percentage Characteristic**  
**Angle Body Valve**  
**Flow Down**

Valve Size Inches	Port Inches (mm)	Travel Inches (mm)	Coefficient	Percentage of Valve Travel
				100%
2	1-7/8 (47.6)	1-1/8 (28.6)	C <sub>v</sub>	48.8

**NOTE:** For full list of sizing coefficients contact Dyna-Flo Control Valve Services.

### ***Our Commitment to Quality***

Dyna-Flo is committed to continuous improvement. While all efforts have been made to ensure the accuracy of the content in this document, modifications or improvements to the information, specifications, and designs may occur at any time without notice. This document was published for informational purposes only, and does not express or imply suitability, a warranty, or guarantee regarding the products or services described herein or their use or applicability.

Neither Dyna-Flo Control Valve Services Ltd., nor any of their affiliated entities assumes responsibility for the selection, use and maintenance of any product. Responsibility for selection, use and maintenance of any product remains with the purchaser and end-user.



# Model 390/391 Control Valves

## MODEL NUMBERING SYSTEM

**SAMPLE PART NUMBER: 390-3AFL-SFP2-CES4**

						<b>MODEL</b>		<b>390</b>			
<b>390</b>	MODEL 390				<b>391</b>	MODEL 391					
<b>BODY STYLE</b>											
-	GLOBE		<b>A</b>	ANGLE							
<b>VALVE SIZE</b>											
<b>2</b>	2 INCH		<b>3</b>	3 INCH		<b>4</b>	4 INCH				
					<b>6</b>	6 INCH					
<b>ASME RATING</b>											
<b>A</b>	900		<b>B</b>	1500		<b>C</b>	900 / 1500				
<b>END CONNECTION</b>											
<b>F</b>	RF		<b>J</b>	RTJ		<b>L</b>	BWE SCH 80				
<b>P</b>	BWE SCH 160								<b>U</b>	BWE SCH 120	
<b>BODY MATERIAL</b>											
<b>L</b>	LCC		<b>W</b>	WCC		<b>M</b>	CF8M				
					<b>9</b>	WC9					
<b>BOLTING</b>											
-	B7 / 2H		<b>A</b>	B7M / 2HM		<b>B</b>	B8M / 8M				
<b>K</b>	B7 / 2H FLUOROKOTE #1		<b>L</b>	B7M / 2HM FLUOROKOTE #1							
<b>TRIM</b>											
<b>S</b>	TRIM SPEC S		<b>C</b>	TRIM SPEC C		<b>N</b>	TRIM SPEC N				
					<b>A</b>	TRIM SPEC A					
<b>PORT SIZE</b>											
<b>F</b>	FULL PORT										
<b>PACKING STYLE</b>											
<b>P</b>	SINGLE PTFE V-RING (PRESSURE)				<b>J</b>	DOUBLE PTFE V-RING (PRESSURE)					
<b>G</b>	SINGLE GRAPHITE (PRESSURE)				<b>V</b>	DOUBLE PTFE V-RING (VACUUM)					
<b>R</b>	DOUBLE PTFE V-RING (VACUUM / PRESSURE)				<b>L</b>	LIVE LOADED PTFE V-RING (PRESSURE)					
<b>T</b>	LIVE LOADED GRAPHITE (PRESSURE)				<b>D</b>	LIVE LOADED DUPLEX (PRESSURE)					
<b>K</b>	LIVE LOADED KALREZ® (PRESSURE)				<b>F</b>	LIVE LOADED KALREZ® FIRE SAFE (PRESSURE)					
<b>YOKE BOSS SIZE</b>											
<b>2</b>	2-13/16" (1/2" STEM)		<b>3</b>	3-9/16" (3/4" STEM)		<b>5</b>	5" (1" STEM)				
<b>PAINT</b>											
-	DFPS-01 (STANDARD)				<b>2</b>	DFPS-02 (SEVERE SERVICE)					
<b>3</b>	DFPS-03 (HIGH TEMPERATURE)										
<b>BACKUP RING / SEAL RING / PISTON RING</b>											
<b>C</b>	S31600 / CARBON-FILLED PTFE - ELGILOY				<b>K</b>	S31600 / KEL-F - ELGILOY					
<b>R</b>	S31600 / CARBON-FILLED PTFE - ELGILOY W/ PEEK AE RINGS										
<b>G</b>	DOUBLE GRAPHITE PISTON RINGS (391 ONLY)				<b>H</b>	TRIPLE GRAPHITE PISTON RINGS** (391 ONLY)					
<b>CHARACTERISTIC</b>											
<b>E</b>	EQUAL PERCENT		<b>L</b>	LINEAR		<b>M</b>	MODIFIED EQ. PERCENT				
<b>2</b>	ANTI-CAVITATION 2 STAGE				<b>3</b>	ANTI-CAVITATION 3 STAGE					
<b>H</b>	LOW-NOISE III A1		<b>B</b>	LOW-NOISE III B1		<b>P</b>	LOW-NOISE III B3				
					<b>I</b>	LOW-NOISE III C3					
<b>D</b>	LOW-NOISE III D3										
<b>BONNET STYLE</b>											
<b>S</b>	STANDARD		<b>T</b>	STANDARD TAPPED		<b>E</b>	EXTENSION STYLE 1				
<b>SHUT-OFF CLASS</b>											
<b>2</b>	CLASS II (391 ONLY)		<b>3</b>	CLASS III (391 ONLY)		<b>4</b>	CLASS IV				
					<b>5</b>	CLASS V					
<b>NOTE:</b> Modified Equal Percent is a factor of travel and requires no special parts or trim options that differ from Equal Percent.											
** - Triple Piston Rings are only available for valve sizes 3" to 6", for Class IV shutoff requirements for 2" valve sizes refer to Model 392 valves.											